

Dryer Timers

Adjustable Time Settings

Greenwald
Exclusive

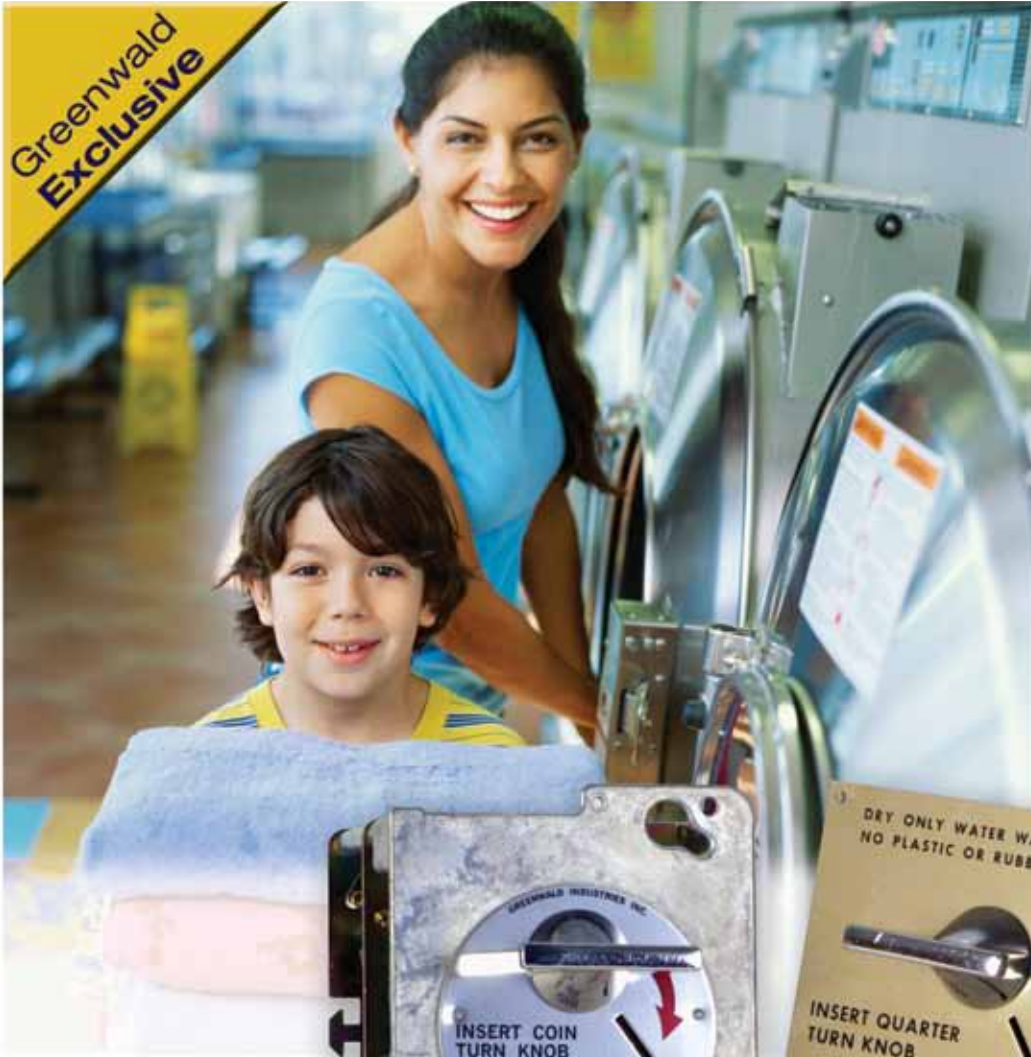

Features

Coin-activated electromechanical timers

Accepts most currency including many international coinage

1-4 coin start (specify)

Different timing CAMs allow almost any time interval

5900P Round Face Timer



5900P Square Face Timer



Greenwald Industries' 5900 Series Timers offer easy to increase or decrease time settings on electrical appliances. Accumulation period feature is convenient to appliance user, since extended operation can be obtained without the need to deposit coins after each time period.

When ordering, please specify:

- Timing
- Voltage
- Number of coin(s) to start (1-4)
- Type of coinage

Full 1-year warranty. Made in the USA.



Specification Details for QuarterMasters™ 5900 P Series

Series	Round Face	Square Face
Part Number: 1 Switch	59 - 3100 - 2	
Part Number: 2 Switches	59 - 3200 - 2	59 - 3200 - 15
Part Number: 3 Switches	59 - 3300 - 2	59 - 3300 - 15
Voltage†	110VAC or 220VAC, 50/60 Hz	110VAC or 220VAC, 50/60 Hz
Average Power Consumption	3 watts	3 watts
Mounting	Standard	Standard
Net Weight	1.7 lbs	1.7 lbs
Options:		
Token	•	•
Foreign Currency*	•	•
24V AC†	•	•
2 Coin Start	•	•
3 Coin Start	•	•
Time Accumulating Limiting	•	•
Warranty	1 Year	1 Year

*Contact factory for international currency.

Part Number Example



Timing Formula

RPM divided by **Pins** equals **Minutes**

Identifying On and Off Positions:

In the OFF position, the **switch arm (A)** is fully depressed against the **switch button (B)**. There is no conductivity between **COM** and **NC**. When a coin is deposited (1 coin to start), the switch arm is released and the internal contacts close. There is now conductivity between **COM** and **NC**, and the meter is **on**.

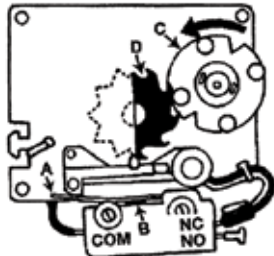

To turn the meter off, remove accumulated time:

First disconnect meter from the power source. Rotate the white nylon **timing CAM (C)** until both toothed **ratchet wheels (D)** are advanced. Now reconnect it to the power source. The meter (and the appliance) will run for a brief period of time (2 to 3 minutes with a 1/60 RPM motor) and then shut off. The unit is now ready for operation.

Simple Instructions to Change Timing:

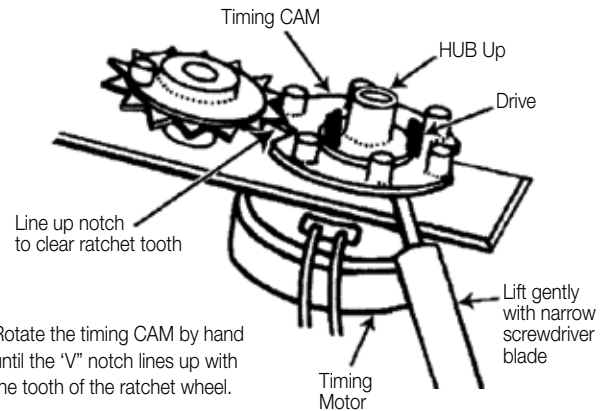

1. Rotate the timing CAM by hand until the "V" notch lines up with the tooth of the ratchet wheel.
2. Pry off the timing CAM, making sure that the "V" notch clears the ratchet tooth.
3. Replace it with the CAM that will give you the desired timing.

Why Greenwald Industries

Full Line of Laundry Vending Products:
Coin, SmartCards, and Access Control Systems
Coin-Op Leader for Over 50 Years
Made in the USA

GREENWALD INDUSTRIES

212 Middlesex Avenue | Chester, CT 06412 USA | Tel: (860) 526-0800 | Fax: (860) 526-4205
Toll-Free Tel: 1-800-221-0982 | Toll-Free Fax: 1-800-445-1340
www.greenwaldindustries.com

United States & Canada Customer Service & Technical Assistance:
Monday-Friday, 8am to 5pm EST.

Contents, specifications and availability are subject to revisions serving the technical improvement.
Not responsible for any typographical errors.

